

Ag Leader[®]



Relay
User Guide
PN 2006261—ENG Rev. B

© 2018 Ag Leader Technology
2202 South Riverside Drive
Ames, Iowa 50010 USA

Relay User Guide	1
Notice	1
General Notices	1
Export Restrictions	1
FCC Notices	1
Industry Canada	2
CE	2
A-Tick Marking	2
Safety	2
WEEE Notice	2
REACH	3
RoHS	3
UHF Radios	3
400 MHz Radios	3
900 MHz Radios	4
Customer Support	4
Contact Information	4
Service	4
Conventions Used In This Manual	4
Cautions and Warnings	4
Cross-references and Web Links	4
Viewing this Manual Online	5
Product Registration	5
Overview	5
Features	5
Connector Overview	5
RTK Radio Mount	6
Relay Connectors	7
Installation and Setup	7
Relay Setup	7
Simplified Relay Setup	8
Attach and Connect RELAY to GPS 7500	9
Connect the RELAY to the Radio Antenna Mount	11
Power Up the RELAY	12
Configuration	12
Connect Power	12
Power Supply Requirements	12
Status Indicator	12
Relay Radio Specification	13
Physical and Electrical Specifications	14
Mechanical Specifications	15
Connector Pin Outs	16
Relay	16

Relay User Guide

Notice

General Notices

The following notices apply to the Relay.



WARNING! Changes or modifications to this equipment not expressly approved by Ag Leader could result in violation of FCC, Industry Canada and CE Marking rules and void the user's authority to operate this equipment.



WARNING! Relay products are available in several different radio configurations.

Regulations for legal operation of these radio devices vary by country and the applicable local frequency management authorities. They may operate either on license free channels or on channels where the operation requires a license. Radio transceiver modules shall only be operated at frequencies allocated by local authorities, and without exceeding the given maximum allowed output power ratings.



WARNING! Relay equipment should be installed under the guidance of experienced, qualified professionals to ensure that applicable licensing considerations are properly addressed, and that operation of the installed system configuration, (including selected antennas), will be compliant with local regulatory and safety requirements. It remains the installer's responsibility to ensure that an installation operates within EIRP emission limits, and that appropriate separation distances for personal safety are maintained.



WARNING! Users of UHF 400 MHz radio transceiver modules in North America should be aware, that due to the allocation of the frequency band 406.0 – 406.1 MHz for government use only, the use of radio transceiver module on this frequency band without a proper permit is strictly forbidden.

Export Restrictions

Relay UHF radio variants may be subject to control by the Export Administration Regulations (EAR) and/or the International Traffic in Arms Regulations (ITAR). Export, re-export, or transfer of these products without required authorization from the U.S. Department of Commerce, Bureau of Industry and Security, or the U.S. Department of State, Directorate of Defense Trade Controls, as applicable, is prohibited. Any party exporting, re-exporting, or transferring these products is responsible for obtaining all necessary U.S. government authorizations required to ensure compliance with these and other applicable U.S. laws. Consult with your legal counsel for further guidance.



WARNING! Changes or modifications to this equipment not expressly approved by Ag Leader could result in violation of FCC, Industry Canada and CE Marking rules and void the user's authority to operate this equipment.

FCC Notices

This device complies with part 15 of the FCC Rules. Operation is subject to the following two conditions: (1) this device may not cause harmful interference, and (2) this device must accept any interference received, including interference that may cause undesired operation.

The Relay has been tested and found to comply with the emission limits for a Class B digital device, pursuant to part 15 of the FCC Rules. The Class B limits are designed to provide reasonable protection against harmful interference in a residential installation.

This equipment generates, uses, and can radiate radio frequency energy and, if not installed and used in accordance with the instructions, may cause harmful interference to radio communications. However, there is no guarantee that interference will not occur in a particular installation. If this equipment does cause harmful interference to radio or television reception, which can be determined by turning the equipment off and on, the user is encouraged to try to correct the interference by one or more of the following measures:

- Re-orient or relocate the Relay
- Increase the separation between the equipment and the Relay

-
- Connect the equipment to an outlet on a circuit different from that to which the Relay is connected
 - Consult the dealer or an experienced radio/TV technician for help



WARNING! Changes or modifications not expressly approved by the party responsible for compliance could void the user's authority to operate the equipment.



CAUTION! In order to maintain compliance as a Class "B" digital device, shielded cables should be used for the RS-232 serial data ports (Belden 1036A or equivalent) and twisted pair cable should be used for the CAN port (shielded twisted pair will improve CAN performance in electrically harsh environments). I/O signals should be referred to signal ground (connector pin 5) and not power ground (connector pin 9). If I/O signals route to different areas of the vehicle, dedicated signal grounds for I/O should be spliced into a common connection to connector pin 5 at a point close to the receiver.

Industry Canada

Relay Class B digital apparatus complies with Canadian ICES-003.

Relay appareil numérique de la classe B est conforme à la norme NMB-003 du Canada.

Under Industry Canada regulation, Relay radio transmitters may only operate using an antenna of a type and maximum (or less) gain approved for the transmitter by Industry Canada. To reduce the potential radio interference to other users, the antenna type and gain should be chosen so that the equivalent isotropically Radiated Power (RP) is not more than necessary for successful communication.

CE

The enclosures carry the CE mark.

"Hereby, Ag Leader declares that this Relay is in compliance with the essential requirements and other relevant provisions of the R&TTE Directive 1999/5/EC, EMC Directive 2004/108/EC and the RoHS Recast Directive 2011/65/EU."

A-Tick Marking

The HSPA model of the Relay carries the A-Tick compliance mark.

Safety



WARNING! Switch OFF your Relay when around gasoline or diesel-fuel pumps and before filling your vehicle with fuel. Respect restrictions on the use of radio equipment in fuel depots, chemical plants or where blasting operations are in progress.



WARNING! There may be a hazard associated with the operation of your Relay close to inadequately protected personal medical devices such as hearing aids and pacemakers. Consult the manufacturers of the medical device to determine if it is adequately protected.



WARNING! Operation of your Relay close to other electronic equipment may also cause interference if the equipment is inadequately protected. Observe any warning signs and manufacturers' recommendations.



WARNING! RF Exposure

Maximum permissible antenna gains and minimum permissible separation distances between antennas and all persons will vary by radio variant, and must be addressed on a radio specific basis to ensure compliance with FCC, IC, and other applicable RF exposure compliance requirements. Devices must not be co-located or operating in conjunction with any other antenna of transmitter. Refer to the radio specific notices for additional guidance.

WEEE Notice

If you purchased your Relay in Europe, please return it to your dealer or supplier at the end of its life. The objectives of the European Community's environment policy are, in particular, to preserve, protect and improve the quality of the

environment, protect human health and utilize natural resources prudently and rationally. Sustainable development advocates the reduction of wasteful consumption of natural resources and the prevention of pollution. Waste electrical and electronic equipment (WEEE) is a regulated area. Where the generation of waste cannot be avoided, it should be reused or recovered for its material or energy.

WEEE products may be recognized by their wheeled bin label ().

REACH

Ag Leader strives to comply with the EU Directive EC 1907/2006 on chemicals and their safe use as per the Registration, Evaluation, Authorization and Restriction of Chemical substances (REACH) for its products, including the GPS 7500 receiver. Since REACH SVHC lists are updated occasionally, please contact Ag Leader Customer Support if you require further information.



WARNING!: Cables may contain DEHP (CAS Number 117-81-7) in concentrations above 0.1% w/w.

RoHS

The SMART family are compliant with the European Union (EU) Restriction of Hazardous Substances (RoHS) Directive 2011/65/EU.

Visit the NovAtel Web site at www.novatel.com/products/weee-and-rohs/ through Products | WEEE and RoHS for more information.

UHF Radios

400 MHz Radios

400 MHz UHF Relays variants contain a radio transceiver module with the following modular approvals:

- FCC ID: MRBSATEL-TA23
- IC ID: 2422A-SATELTA23

The radio transceiver module has been designed to operate on 403-473 MHz, the exact use of which differs from one region and/or country to another. The user of a radio transceiver module must take care that the said device is not operated without the permission of the local authorities on frequencies other than those specifically reserved and intended for use without a specific permit.

The radio transceiver is allowed to be used in the following countries, either on license free channels or on channels where the operation requires a license. More detailed information is available at the local frequency management authority.

- Countries: AT, BE, BG, CA, CH, CY, CZ, DE, DK, EE, ES, FI, FR, GB, GR, HU, IE, IS, IT, LT, LU, LV, MT, NL, NO, PL, PT, RU, RO, SE, SI, SK, US



WARNING!: Restricted Use

Users of UHF 400 MHz radio transceiver modules in North America should be aware, that due to the allocation of the frequency band 406.0 – 406.1 MHz for government use only, the use of radio transceiver module on this frequency band without a proper permit is strictly forbidden.



WARNING!: RF Exposure

To comply with FCC and IC RF exposure compliance requirements, maximum antenna gain is 14 dBi and separation distance of at least 1 meter must be maintained between the antenna of this device and all persons, (when Relay 400 MHz is used in a transmitter/base station configuration). Professional installation is required, and radio power must be adjusted by the installer, based on the antenna system gain, so as not to exceed FCC prescribed output power limits. This device must not be located or operating in conjunction with any other antenna or transmitter. Installers shall ensure that the device is not configured as a transmitter/base station when installed on a rover, and personal separation distances of only 20 cm may be expected.

900 MHz Radios

900 MHz UHF Relays variants contain a radio transceiver module with the following module approvals:

- FCC ID: KNYAMM0921TT
- IC ID: 2329B-AMM0921TT



WARNING!: RF Exposure

Antennas used with the RELAY UHF 900 MHz variant must have the following characteristics to remain in compliance with FCC requirements and regulations; Antenna gain does not exceed 12 dBi for Yagi antennas and 8.15 dBi for Omni antennas, and, Overall system Equivalent Isotropically Radiated Power (EIRP) does not exceed 36 dBm. Professional installation is required, and radio power must be adjusted by the installer, based on the antenna system gain, so as not to exceed FCC prescribed output power limits. The antenna(s) used for this transmitter must be installed to provide a separation distance of at least 23 cm from all persons and must not be collocated or operating in conjunction with any other antenna or transmitter.

Customer Support

Contact Information

Use one of the following methods to contact Ag Leader Support:

- ph: (515) 232-5363
- fax: (515) 232-3595
- e-mail: support@agleader.com

Service

There are no user-serviceable parts inside the receiver. Contact the manufacturer for a Return Material Authorization (RMA).

- ph: (515) 232-5363
- fax: (515) 232-3595
- e-mail: support@agleader.com

Conventions Used In This Manual

Cautions and Warnings

The operators manual uses the following text formatting schemes to call attention to information related to simplifying system operation and proper operating practices to prevent accidental data loss. If in doubt about the results of performing an action or deleting an item from the system, back up all system files to the USB external drive prior to proceeding with the action.



NOTE!: Provides informative tips to assist with system setup, calibration, and operation.



CAUTION!: Indicates specific settings, calibrations, and procedures that must be followed for proper system performance and operation.



WARNING!: Indicates specific instructions to avoid accidental loss of data and system configurations settings.

Cross-references and Web Links

Throughout this manual, numerous cross-references are provided to other pages or sections. These cross-references are always shown in blue, italic text; and list the title and page number as in the following example: Refer to [“Conventions Used In This Manual” on page 4](#). If you are viewing this manual in PDF format, you can click on this blue text and go directly to the link.

Links to web sites are shown in blue, italicized, and underlined text, as in the following example: To view the web site, go to: www.agleader.com.

Viewing this Manual Online

This operators manual can be viewed online at Ag Leader's Web site. To view and/or print the Operators Manual online, you will need the Adobe Acrobat or Adobe Reader. The Adobe Reader software comes pre-installed on most personal computers. If Adobe Reader is not installed on your computer the program is available for download at no charge. A link to the Adobe download site is located at the Ag Leader Web site.

Product Registration

Contact your Ag Leader dealer for technical support.

When registering your Ag Leader Technology products by one of the following methods, you can elect to receive notice of any new product updates or features.

Register by mail:

Ag Leader Technology
2202 South Riverside Dr.
Ames, IA 50010

Register by Fax: 515-232-3595

Register at the Ag Leader Web site at <http://www.agleader.com>

Overview

The device is an RTK rover radio module for GPS 7500 antennas. The Relay attaches to the GPS 7500 to create a single unit for easy system integration. The RELAY provides the GPS 7500 with radio connectivity to support RTK corrections.

When the RELAY and GPS 7500 are connected, the optional GPS 7500 interface cable is connected to the RELAY and is used to deliver pass-through power, RS-232 ports, CAN Bus and ground speed output from the GPS 7500.

The GPS 7500 COM3 RS-232 port is not available when the RELAY is connected.

Features

The main features are:

- Satel UHF 400 MHz or 900 MHz radio options to support RTK corrections
- Can be mounted to a vehicle using integrated magnets
- Water and dust tight enclosure
- Integrated NMO radio antenna mount

The TNC to NMO cable is installed in the factory. It can be removed to install and optional external antenna.

Connector Overview

The RELAY uses the same cable for power and communication as the GPS 7500. Use the Ampseal connector at the front of RELAY to connect to the GPS 7500.

RTK Radio Mount

The RELAY internal 400 MHz or 900 MHz radio can be used to receive RTK corrections from a compatible base station. An external antenna must be connected to the back of the RELAY.

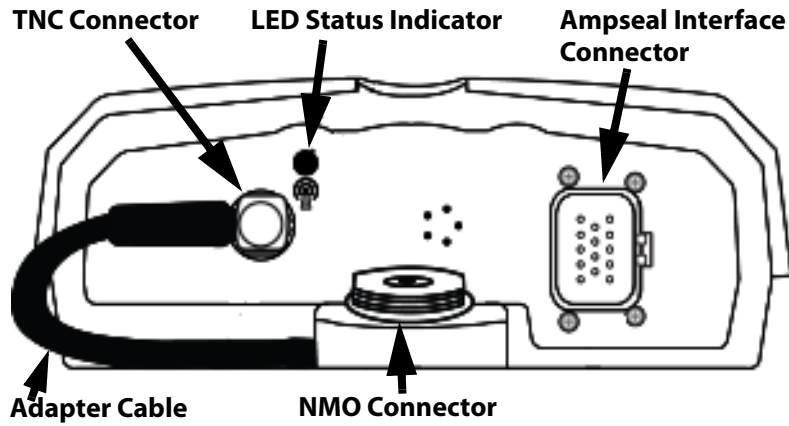

Back of Relay for connecting
RTK Antenna

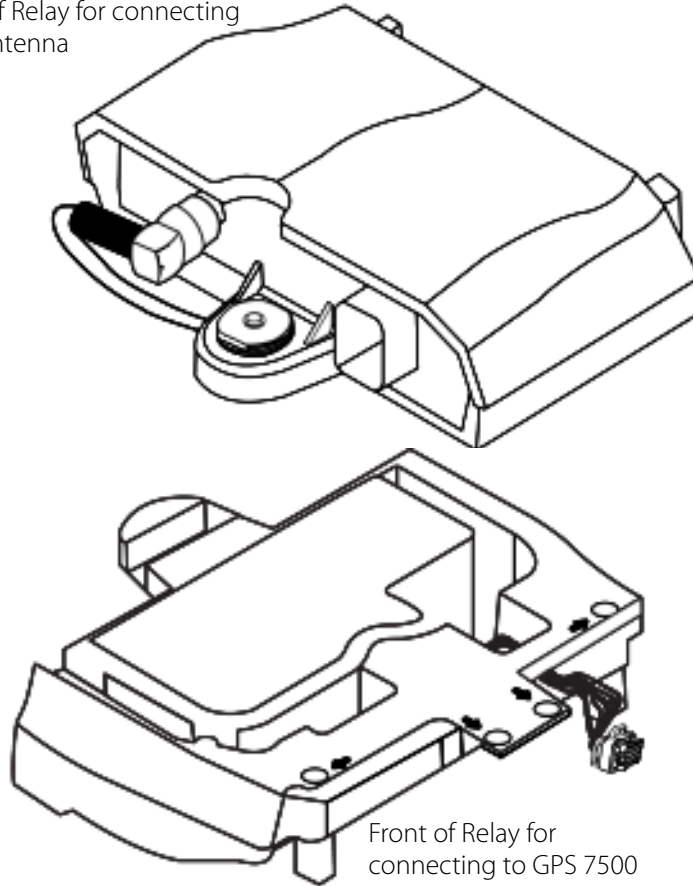

Relay Connectors

Connector	Description
GPS 7500 Antenna Port	14-pin Ampseal connector Connects to the 14-pin connector on the receiver.
COM and Power Port	14-pin Ampseal connector Connects to the cable that provides power for the Relay and receiver.
Radio Antenna Port	Connects the radio and cell modem in the Relay to the external radio antenna.

Installation and Setup

Relay Setup

Complete the following steps to connect and power the Relay.

1. Connect the receiver to the Relay.
2. Mount the Relay on a secure, stable structure with an unobstructed view of the sky from horizon to horizon.
3. Connect the interface cable to the COM and Power port on the back of the Relay.
4. Connect the Relay to the external antenna.
5. Connect the display GPS cable to the display GPS serial port. The power LED on the Relay glows red when the Relay is properly powered.

Simplified Relay Setup

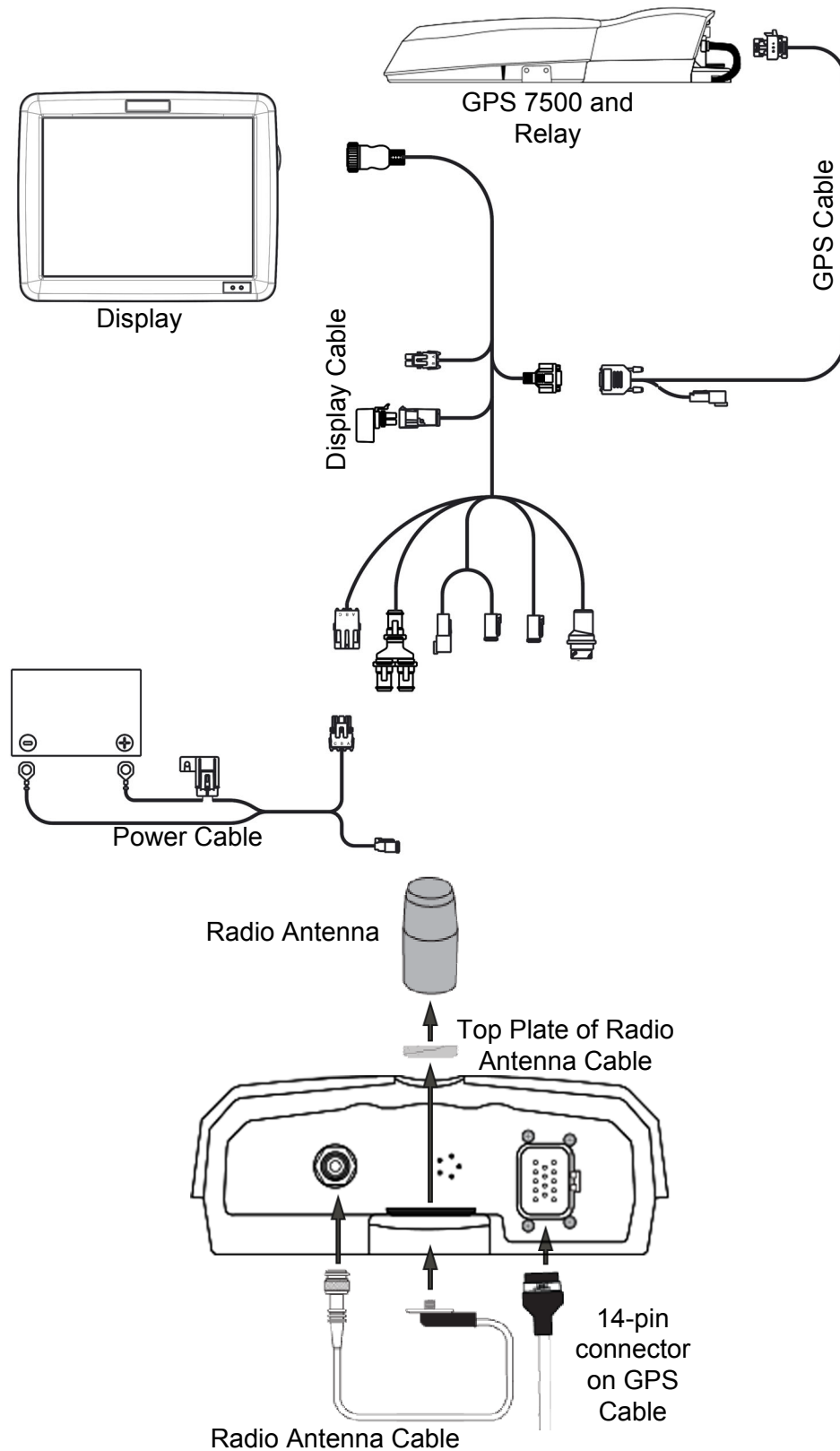

NOTE!: Minimum conductor size for all signal wiring is 0.5 mm/20 AWG. Minimum conductor size for power wiring

is 1.25 mm/16 AWG. For user fabricated cables, all wire insulation sizes in the Tyco 14-pin connector must conform to the manufacturer's recommendations for insulation diameter range (or watertight seal integrity will be compromised).

Attach and Connect RELAY to GPS 7500

NovAtel's RELAY rover radio module attaches to the GPS 7500 to create a single unit for easy system integration.

Before attaching the RELAY to the GPS 7500, make note of the SSID and password (passkey) found on the label on the "connector" back side of the GPS 7500.

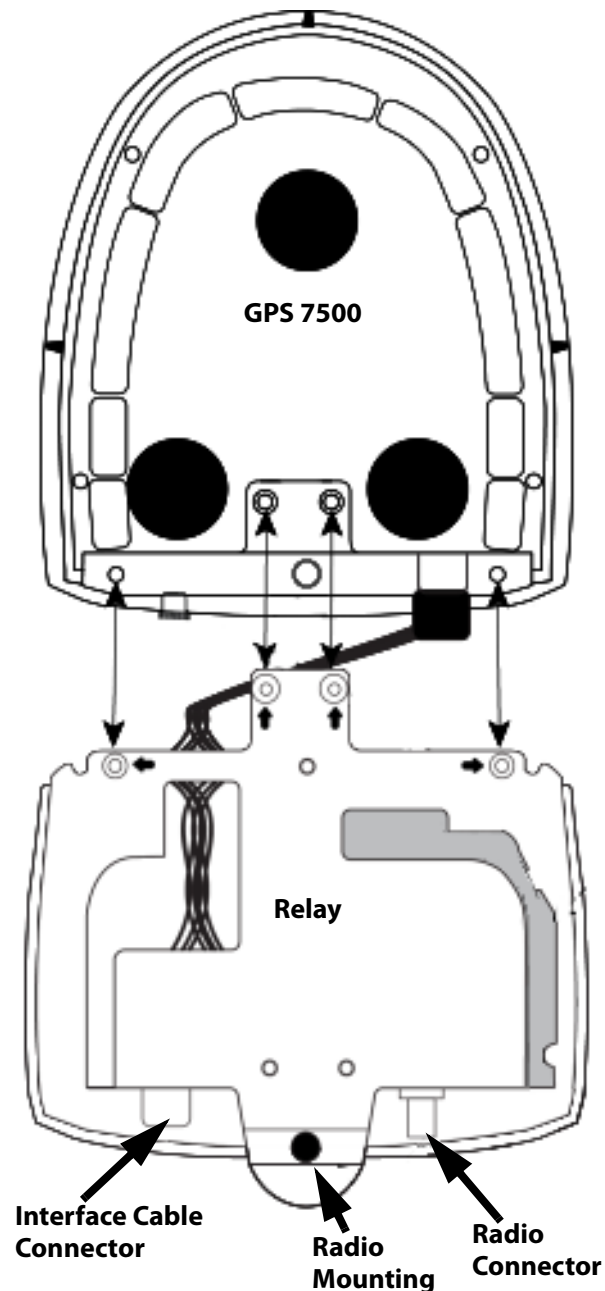

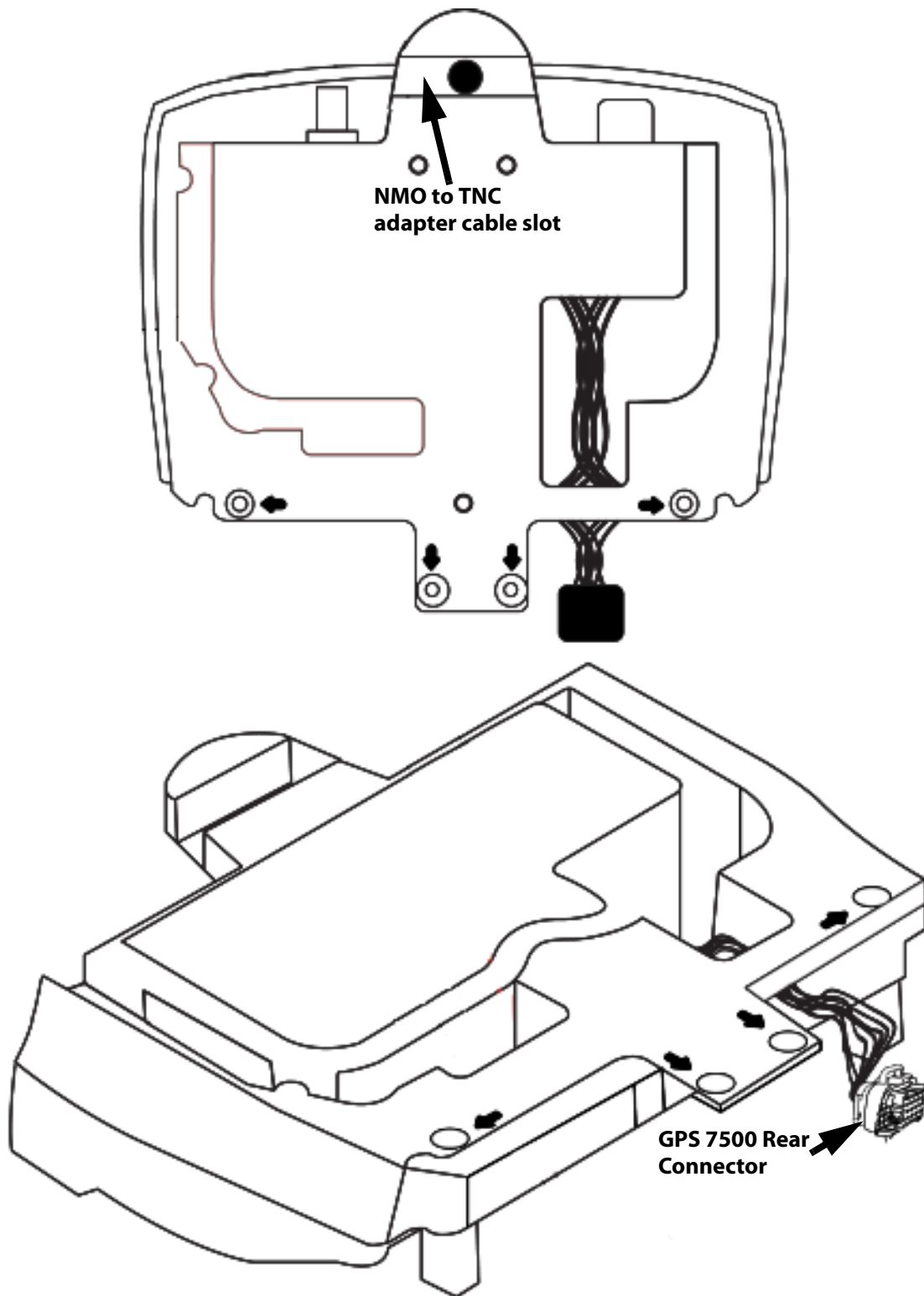

1. Ensure cable connection for the Ampseal interface is complete.
2. Tilt the RELAY unit slightly up and slide onto the GPS 7500 unit in the locations marked by the four arrows.
3. Hand fasten the M4 screws (x4). Bit required: M2.5 Hex, torque = 10 to 12 in-lb. Failure to properly install the four screws may cause damage.

Once complete, flip the combined GPS 7500/RELAY over. The optional NovAtel interface cable or the vehicle's cable attached to the navigation system can be used to connect to the RELAY and power the combined units.

To prevent damage or cable fatigue, ensure any loose cables are secured.

Connect the RELAY to the Radio Antenna Mount

To receive UHF radio signals, the RELAY must be connected to a radio antenna. The NMO to TNC Adapter cable comes factory installed. To use an optional external antenna, the cable can be removed. Use the information below to disconnect or reconnect the cable if required later.

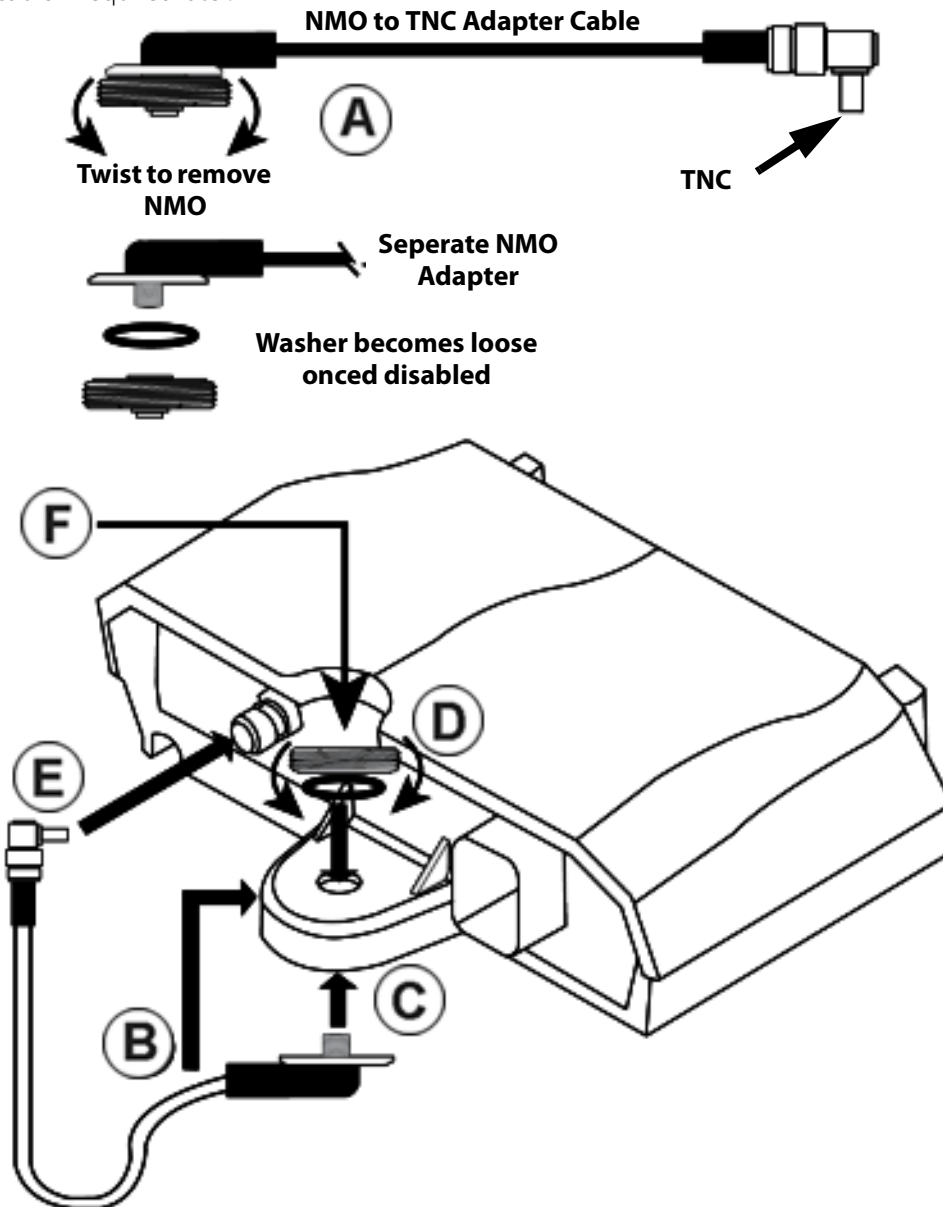

- A.** Separate the NMO to TNC Adapter cable.
- B.** From below, slide the now separated NMO end of adapter cable into the slot at the bottom of the RELAY.
- C.** Push the NMO end of the adapter cable up and through the hole in the RELAY.
- D.** Ensure the white washer is in place before attaching the separated part of the NMO cable onto the top of the protruding end of the adapter cable. Hand turn to tighten.
- E.** Connect the TNC end of the cable to the GPS 7500. Hand turn to tighten.
- F.** Attach UHF Radio 400 MHz or 900 MHz antenna as required.

Power Up the RELAY

Once internal connections between the GPS 7500 and RELAY are complete and the two modules tightly attached, connect the GPS 7500 Ampseal interface cable to the back of the RELAY. Apply power and check the front LED on the RELAY for status.

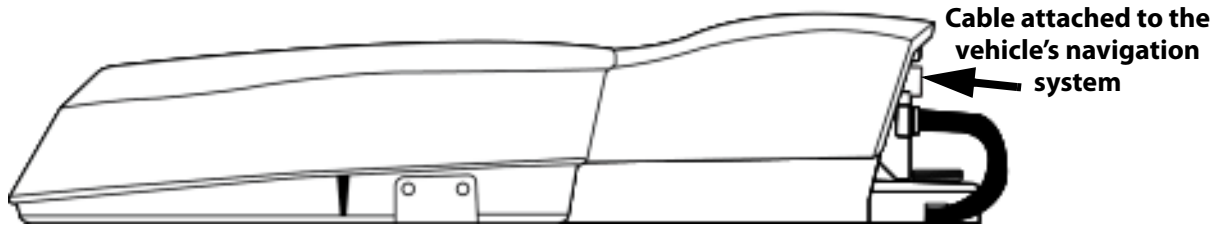

To prevent damage or cable fatigue, ensure any loose cables are secured.

Configuration

The RELAY must be connected to the GPS 7500 and powered up before it can be configured.

To configure the RELAY:

1. The GPS 7500 must be configured to communicate with the RELAY.
2. The GPS 7500 must detect the radio.
3. The radio in the RELAY can be configured or queried.

Connect Power

Power is connected to the Relay through the COM and Power port on the back of the Relay. This power connection provides power to both the Relay and the receiver.

Power Supply Requirements

The Relay requires +9 to +36 VDC input power. The power supply connected to the Relay must be capable of providing enough power for both the Relay and the receiver.



WARNING! The power source must be protected by a 10 A Fast Blow Fuse or damage to wiring may result (not covered by warranty).

Status Indicator



The RELAY has a single LED to indicate the radio status. The LED is located above the radio icon on the back of the RELAY.

LED Status	Description
Solid Green	Power On - Ready - No data transmitting to GPS 7500
Flashing Green	Data is being transmitted between RELAY and GPS 7500
Solid Red	The radio has encountered an error

Relay Radio Specification

Wi-Fi Radio (only on available UHF radio models)

Standards	802.11 b/g/n
Frequency Band	2.4 GHz

CDMA Cellular Radio

Frequency Band	800/1900 MHz
Air Interface	S-95A/B and CDMA2000
Data Support	1xRTT
Sensitivity	CDMA 1x: -108 dBm (typical)

HPSA Cellular Radio

Frequency Band	850 to 1900 MHz Depending by frequency band(s) provided by the network operator. Use the most suitable antenna for the band(s).
Bandwidth	70 MHz in GSM850, 80 MHz in GSM900, 170 MHz in DCS and 140 MHz PCS band
VSWR	Maximum \leq 10:1
	Recommended \leq 2:1
Sensitivity	-107 dBm (typical)
Output Power	Class 4 (2 W) @ 850/900 MHz
	Class 1 (1 W) @ 1800/1900 MHz

400 MHz Radio

Frequency Band	403 to 473 MHz
Transmit Power	1 W
Data Bandwidth	12.5 or 25 kHz
Receive Sensitivity	-113 dBm @ 25 kHz
Compatibility	Satellite 3AS, PacCrest (4FSK, GMSK and FST), TrimTalk 450s (P and T)

900 MHz Rado

Frequency Band	902 to 928 MHz
Transmit Power	1 W
Receive Sensitivity	-108 dBm
Compatibility	Freewave MM2-T

Physical and Electrical Specifications

Physical Description

Size	186.5 L mm x 199.5 W mm x 76.4 H mm
Weight	<850 grams
Status LED	Daylight viewable

Connector Description

Interface Connector	14-pin Tyco Ampseal
External Radio Antenna Cable	TNC female jack, 50 Ω nominal
Optional Ethernet Cable	M12D (M) to (F)

Mounting Specifications

4 x M4 screw insert to GPS 7500
Integrated magnetic mount
Screw mount plate 3-M4

Interface Ports Description

RS-232 dedicated ports	2
CAN Bus NMEA 2000	1
Ground speed output	1
Optional Ethernet	1

Electrical Description

Input Voltage Range	+7 to +30 VDC
Power Consumption	2 W typical

400 MHz Radio Model Description

Frequency Band (receive only)	403 to 473 MHz
Rx Sensitivity	-112 dBm @ 25 kHz -116 dBm @ 12.5 kHz

900 MHz Radio Model Description

Frequency Band (receive only)	902 to 928 MHz
Rx Sensitivity	-108 dBm

Mechanical Specifications

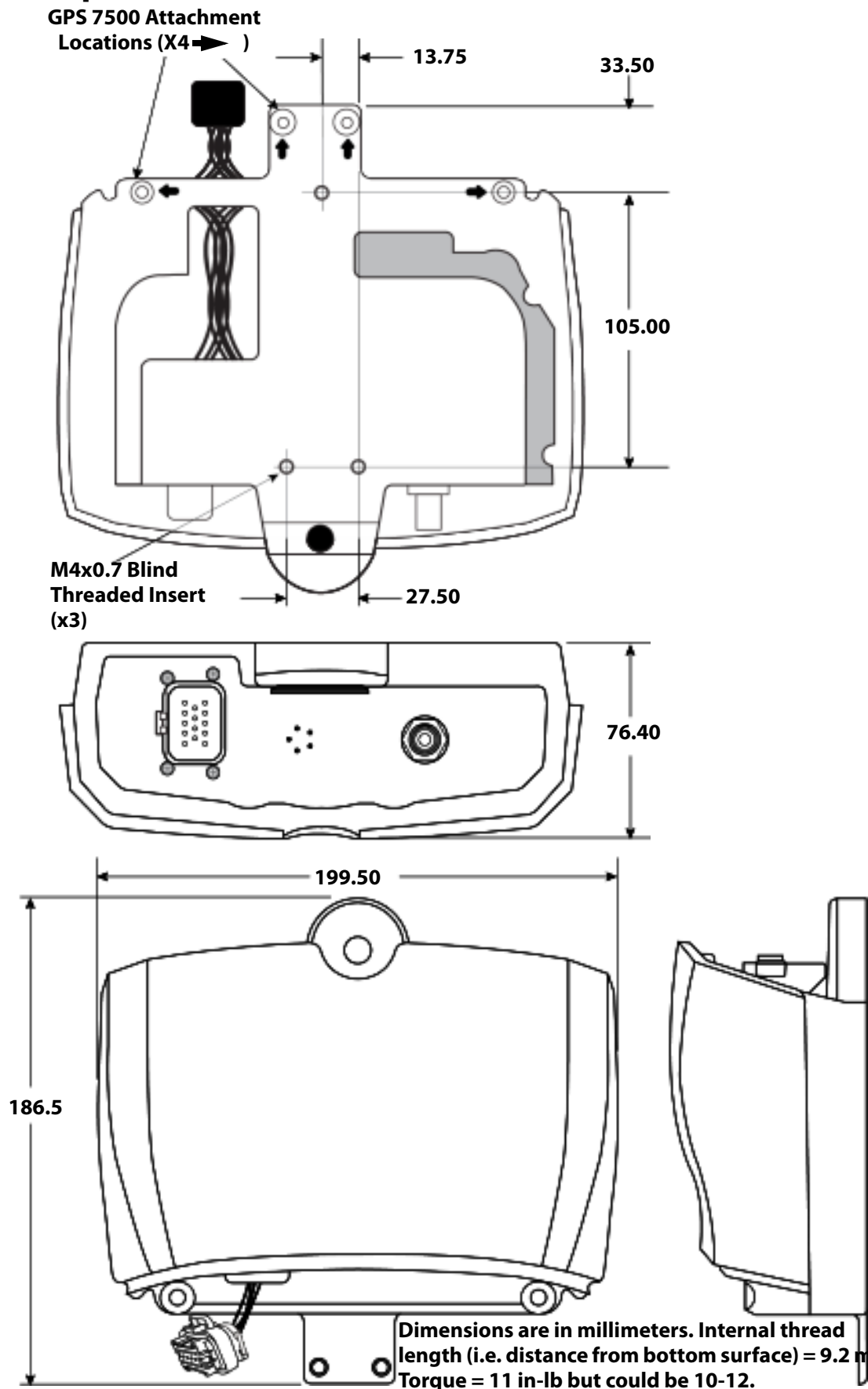

Environmental Specifications

Operating Temperature	-40°C to +70°C
Storage Temperature	-45°C to +80°C
Humidity	MIL-STD-810G(CH1), Method 507.6
Immersion	MIL-STD-810G(CH1), Method 512.6
Ingress Protection Rating	P67, IP69
Shock	MIL-STD-810G(CH1), Method 516.7
Solar Radiation	MIL-STD-810G(CH1), 505.6
Salt Fog	MIL-STD-810G(CH1), 509.6
Sand and Dust	MIL-STD-810G, 510.6
Vibration	MIL-STD-810G, Method 514.7
UV Protection	MIL-STD-810G, 505.6
I/O Protection	ISO 7637 and ISO 15003
Compliance	FCC, ISED, CE Mark, E-Mark

Connector Pin Outs

Pin # Pin Function (Black Ampseal, Male)

1	COM1 TXD Passthrough
2	COM1 RXD Passthrough
3	COM2 TXD Passthrough
4	COM2 RXD Passthrough
5	SIGGND
6	CAN+ Passthrough
7	CAN- Passthrough
8	N/A
9	PWR-
10	Emulated Radar (ER) Passthrough
11	N/A
12	N/A
13	N/A
14	PWR+

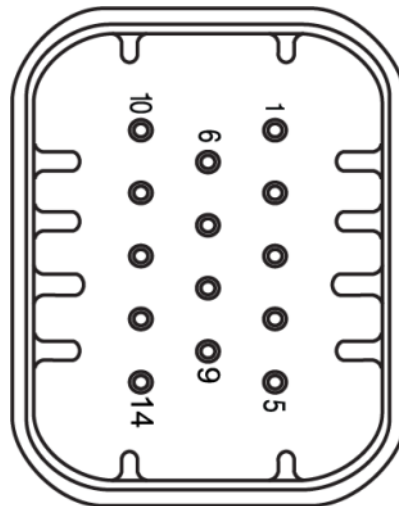

Relay

The following are lists of the replacement parts available for the Ag Leader Relay. Should assistance be required or you need to order additional components, contact Ag Leader Support.

Part Description	Part Number
Relay 400	4005750
Relay 900	4005748
Relay Interface Cable	4004175-118
Relay Radio Antenna Cable	4004211-006
Mounting Plate	4005762
Relay User Manual	2006261
GPS 7500 User Manual	2006260