



## ~ VERSATILE DELTATRACK ~

The Versatile DeltaTrack is a fully integrated purpose-built four track system from Versatile. Available in two models 520DT and 620DT, the DeltaTrack exceeds the performance and durability of existing track systems. The track systems uses the proven Versatile outboard planetary system to maximise power to the ground. Four independent tracks maintain balance and provide constant contact with the ground. The DeltaTrack is built using the most advanced track design in the agriculture industry and features proven Cummins engine technology, rugged CAT® powershift transmissions, and legendary Versatile reliability and serviceability.







## TABLE OF CONTENTS

<b>4-5</b>	POWERTRAIN
<b>6-7</b>	UNDERCARRIAGE SYSTEM
<b>8</b>	TRACK SYSTEM
<b>9</b>	HITCH AND DRAWBAR / HYDRAULICS
<b>10-13</b>	HQ CAB
<b>14-15</b>	CONTROLS
<b>16-17</b>	SERVICE AND MAINTENANCE
<b>18</b>	PARTS AND SERVICE
<b>19</b>	SPECIFICATIONS



# GROUND-BREAKING POWER



## POWERTRAIN

The Versatile DeltaTrack was designed to exceed the performance of existing agricultural track machines. Combining a powerful 15-litre Cummins engine and a smooth shifting 16 x 4 CAT powershift transmission, the DeltaTrack's powertrain outperforms the competition. Designed as a fully integrated track machine the DeltaTrack is the most advanced track tractor on the market today.

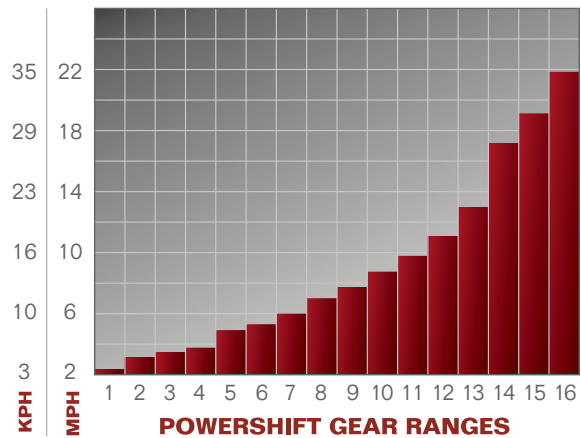

**NO EGR**



## TRANSMISSION AND ENGINE

### Engine

- Industry-leading power bulge and torque rise
- Variable Geometry Turbo for fast response and power on demand

### Transmission

- 40-80% larger in size and weight than the competition
- Programmable transmission settings
- Quick, smooth auto-modulated shifting when needed



## WEIGHT DISTRIBUTION

The steel saddle fuel tanks help the DeltaTrack maintain an even 50/50 weight distribution left to right regardless of fuel level. A crossover tube carries fuel from side to side to maintain even fuel distribution. The tanks are mounted as to not affect the front to rear weight ratio.



## VERSATILE OUTBOARD PLANETARY

The DeltaTrack drivetrain maintains the Versatile outboard planetary system. The outboard planetaries drives power directly above the bogies to maintain equal torque to each track unit.



This minimises the impact of power transfer being disrupted while turning and reduces torque loss, making it easier to turn sharply with large implements and heavy loads.





## WHY THE DELTATRACK UNDERCARRIAGE IS BETTER

The DeltaTrack uses a positive drive system to reduce friction, heat, and wear. Track slippage is eliminated by interlocking track lugs into the drive wheel. The DeltaTrack keeps 6.5 lugs engaged with the drive wheel at all times to eliminate slippage between the track and drive wheel. The DeltaTrack uses the largest drive lugs available (216mm) in the industry to maximise operating life.

- **Drive Sprocket** - A large single piece cast drive sprocket provides a larger wrap angle than competitive track units to increase track life.
- **Idler Wheels** - The large idler wheels used on the DeltaTrack improve the approach angle to reduce the risk of “submarining” in muddy conditions. The large idler wheels and track angle maximise horsepower-to-ground efficiencies.
- **Midrollers** - The large midrollers system are not directly in-line with axle or drive system components to improve the ride and service life of the tractor. Polyurethane coating dramatically reduces midroller wear and maintenance requirements compared to competitive rubber midrollers.
- **Double Axis Bogie** - Two way oscillation provides excellent weight transfer and reduces shock loading. The DeltaTrack double axis bogie system also offers a smooth ride over diverse field conditions.



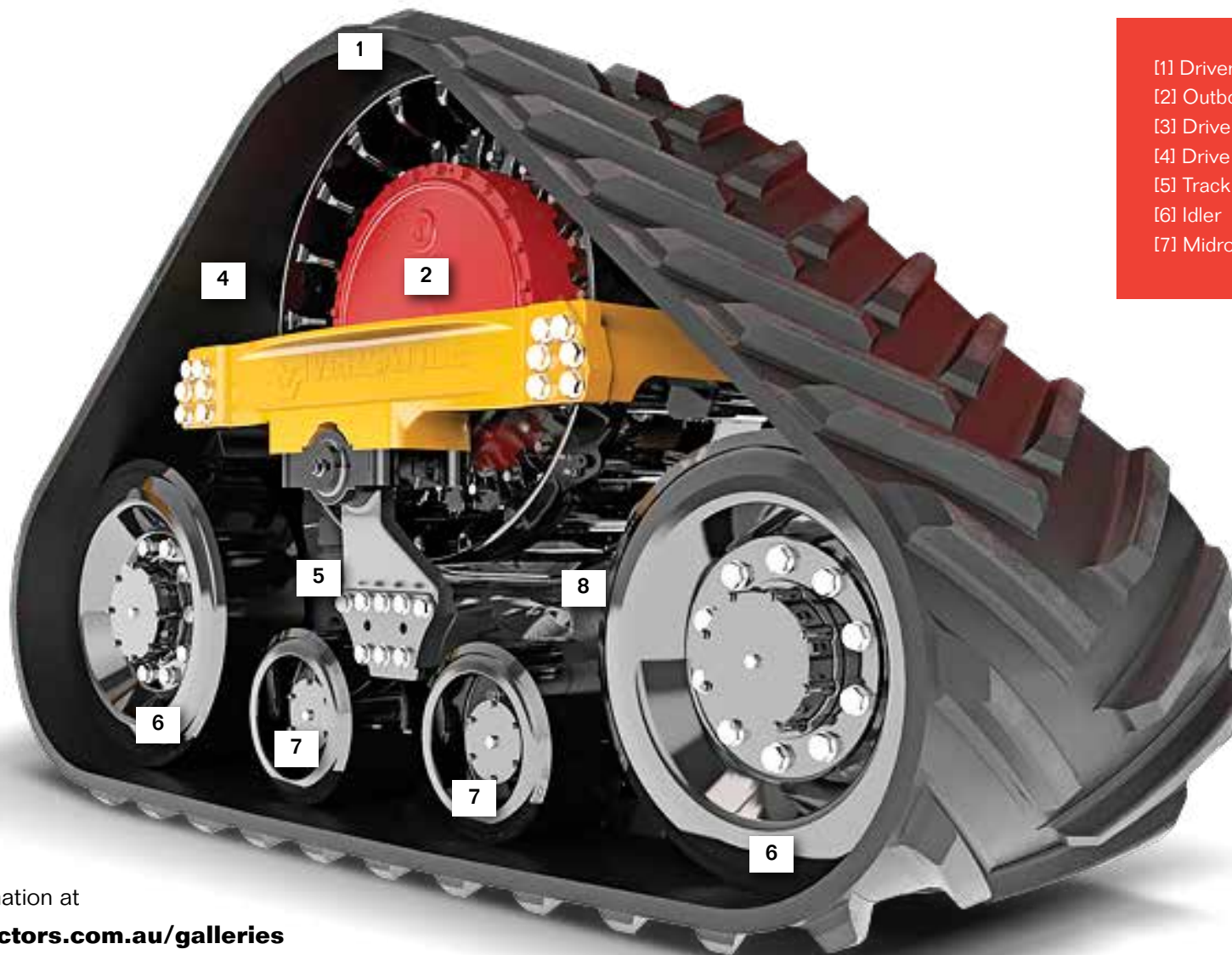

- [1] Driver Wrap
- [2] Outboard Planetary Drive
- [3] Drive Wheel
- [4] Drive Lug
- [5] Track Frame
- [6] Idler
- [7] Midroller



View Deltatrack animation at  
[www.versatiletractors.com.au/galleries](http://www.versatiletractors.com.au/galleries)  
 for full detail of operation

## DOUBLE AXIS BOGIE

Two way oscillation provides better weight transfer and reduces shock loading. Reduced vibrations and frame stress increase operator comfort. The DeltaTrack double axis bogie system also offers a better ride over a variety of obstacles.





## ARTICULATION

Large 3.5" (89 mm) steering cylinders articulate the tractor smoothly and quickly. A maximum articulation angle of 33° means a tight turnaround radius of less than 19' (5.8 m).

## HYDRAULICS

Electro-hydraulics, standard on all models, are ergonomically designed for both comfort and convenience. Finger-tip controls manage the hydraulic functions and hydraulic flow is increased and decreased using the EHR monitor.



**1** DeltaTrack models feature a 3.15" (80 mm) pivot pin.

**2,3** A total hydraulic flow of 53 GPM (201 L/min) is standard, or 106 GPM (401 L/min) with the optional high flow hydraulic system.

Four remote valves are standard, six optional.



## EFFICIENT DRAWBAR PULL

- Well ballasted tractor design
- Powertrain designed for efficient engine-to-ground power transfer
- CAT V drawbar has a 6804 kg vertical load capacity
- Drawbar pull from the center of the tractor maximises the transfer of power to the ground

The image shows the interior of a tractor cab. On the left, there is a large, light-colored dashboard with a prominent circular gauge. In the center, a black steering wheel is mounted on a column. Behind the wheel, a dashboard features a digital display and various control buttons. To the right of the steering wheel is a gear selector lever with red and orange lights. Further right, there is a control panel with several buttons and a joystick. The operator's seat is a large, grey, high-back seat with a textured fabric and adjustable armrests. The floor is covered with a grey, ribbed mat. The background shows a dirt field through the open cab structure.

**RUGGED & RELIABLE  
RESTYLED**





## UNIVERSAL AUTO-STEER

- Universal auto-steer allows for integration to almost any farming system, saving time and money when adding a new Versatile to the fleet
- Plug and play intergration with any system you choose

## IMPROVED STANDARD CAB OFFERING

The DeltaTrack takes advantage of the class leading Versatile HQ Cab. With over 85 sq. ft. of viewable window glass the HQ Cab provides a panoramic view of your fields. A seat mounted right-hand console gives you fingertip control over the entire tractor to help reduce operator fatigue. A semi-active air-ride suspension seat is standard and the HQ Cab also offers a large training seat.

## DELUXE CAB

The new Deluxe Cab is a high-end full-featured cab that provides the operator with every imaginable comfort for long working days. A semi-active air-ride suspension seat and the training seat are both standard in this configuration.

In addition to the connectivity options available in the standard cab, the Deluxe Cab has an 110v AC power outlet and a 5-volt integrated USB port. A subwoofer is also standard to improve sound quality in the cab.

## VENTS

Large multi-directional vents optimise comfort and help create an ideal cab environment.

## RADIO

A conveniently located stereo and high quality sound system help make long days in the cab more enjoyable.

## CONVENIENCE

Four cup holders are standard. The cab also has coat hooks to keep the cab clean and organised.

## OPERATOR SEAT

The operator seat has a 104° swivel range to maximise visibility when towing implements. Air-ride suspension and a heated seat are standard in the Deluxe Cab.

## CAB SUSPENSION



The suspended cab on the DeltaTrack combined with the optimisation of the undercarriage provides the best ride in the industry.

The suspended cab is raised onto the four point shock and spring system that works in tandem with the tuned torque arms that reduce or eliminate pitch and roll movement.

Bringing together Versatile's double-axes bogie system and the suspended cab gives the DeltaTrack a superior system to any track based agricultural tractor on the market.







## WORK LIGHTS

For low-light working conditions, Versatile tractors are equipped with fourteen standard worklights mounted on the grille, front fenders, rear fenders and cab.

For additional safety, rotating magnetic roof-mounted beacon lights are also available (standard on Deluxe cab).



## LED LIGHTING

There are never enough hours in the day so light your way with LED. These lights provide up to ten times more light than conventional headlights.

The LED light package replaces four of the standard halogen work lamps with field illuminating LED lights, one on each fender and two headlights on the grille.



## LARGEST CAB IN THE INDUSTRY

- Excellent 360 degree visibility
- Available heated and ventilated seat
- Directional heating/cooling vents
- Easy to read displays
- Intuitive controls



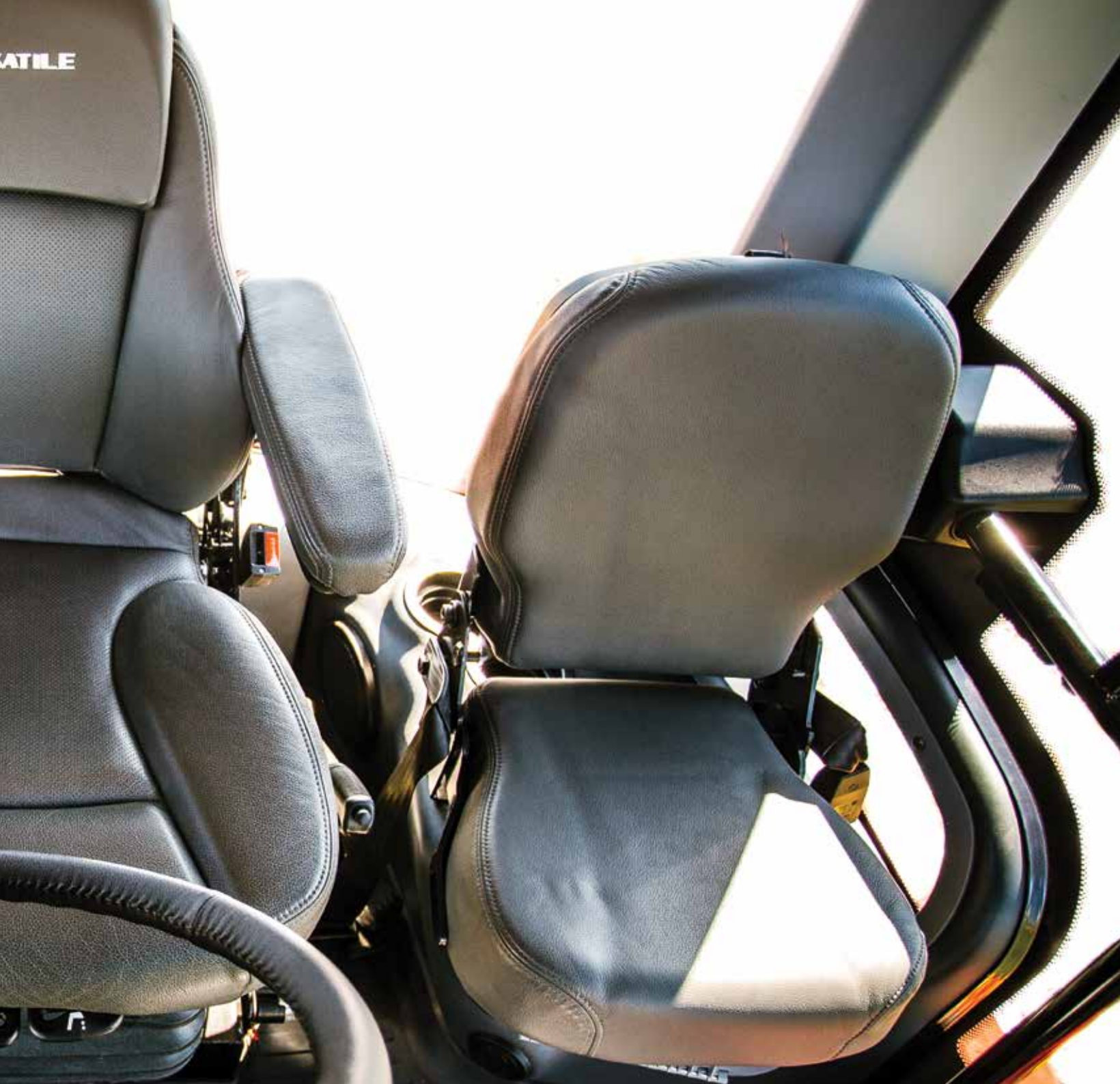

### **VISIBILITY**

A narrow compact front console increases forward visibility and operator comfort.

A 14% increase in glass area and improved mirror positioning give you a 360° of your field.



### **REAR VIEW**

Enjoy a clear view from the seat of your cab.

There is a clear sightline to the drawbar when attaching implements.

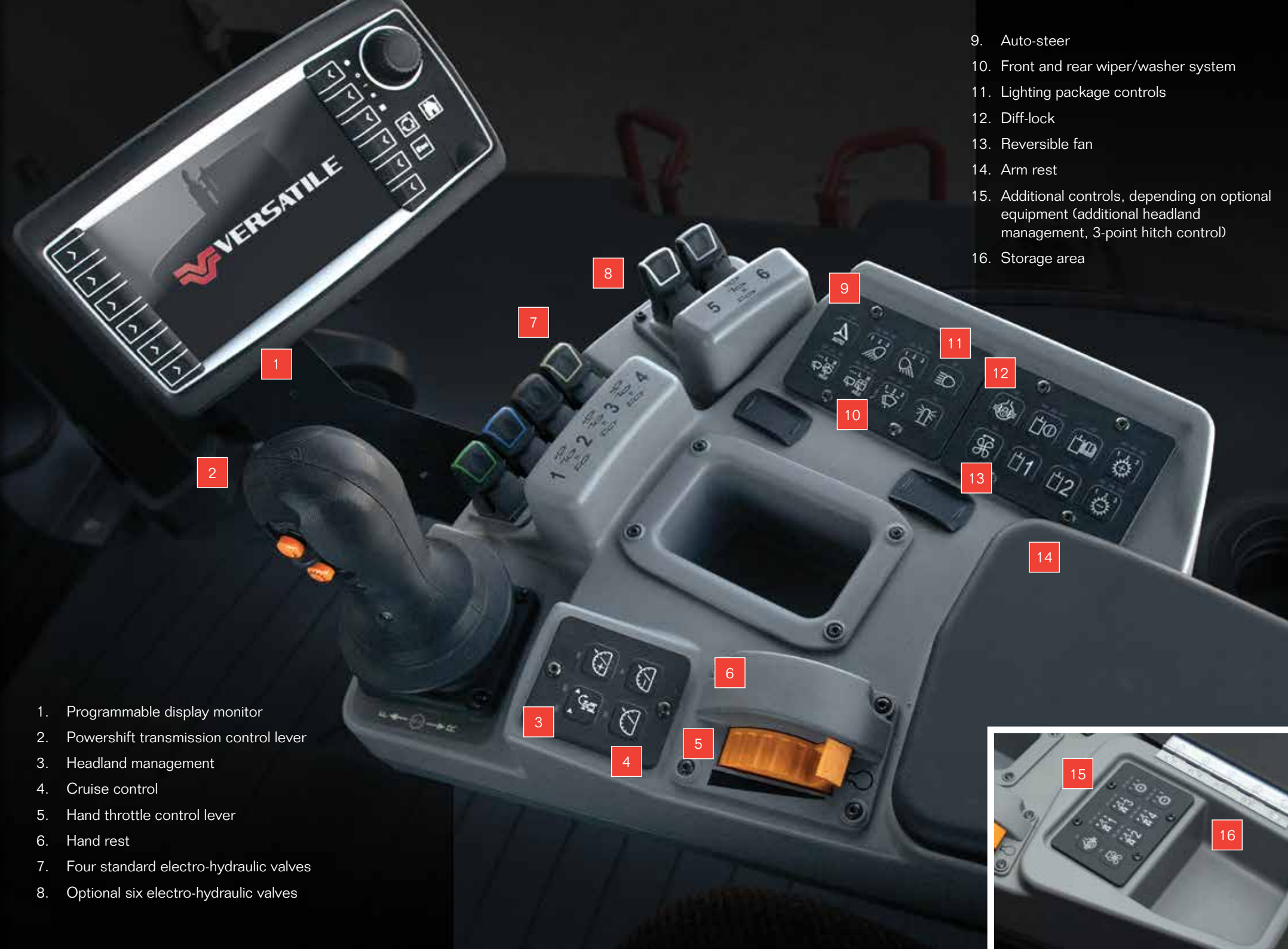

- 1. Programmable display monitor
- 2. Powershift transmission control lever
- 3. Headland management
- 4. Cruise control
- 5. Hand throttle control lever
- 6. Hand rest
- 7. Four standard electro-hydraulic valves
- 8. Optional six electro-hydraulic valves

- 9. Auto-steer
- 10. Front and rear wiper/washer system
- 11. Lighting package controls
- 12. Diff-lock
- 13. Reversible fan
- 14. Arm rest
- 15. Additional controls, depending on optional equipment (additional headland management, 3-point hitch control)
- 16. Storage area





## CONTROLS

Versatile tractors are designed to maintain a comfortable working environment for extended periods of time. By creating an integrated right hand control console, available with the powershift transmission, Versatile puts command of the tractor at your fingertips.

The console moves with the seat so you always have control of your equipment. The arm rest and molded hand rest provide an ergonomic solution with operating the tractor. Additional storage space is available under the arm rest.



### MONITOR

A 7" high-resolution monitor is standard with EHR controls. The monitor can be programmed to display your hydraulic settings for quick reference.

The monitor can also support up to four external cameras. The display is mounted using a shock absorbing suspension and is "sunshine-readable".



### DASH DISPLAY

A programmable center high-resolution display provides readouts on; transmission functions, engine functions, field monitoring and basic tractor functions. RPM, speed, temperature and fuel are all displayed on simple to read analog gauges.



### EHR CONTROLS

Electro-hydraulics are available in a four-valve set up and an optional six-valve configuration.

All DeltaTracks are equipped with the monitor and EHR.



### POWERSHIFT LEVER

A four-function powershift lever gives you quick control over forward, reverse, upshift and downshift functions, eliminating the need for a clutch pedal.



### THROTTLE

A simple responsive hand throttle helps you set your RPMs where you need them for various fieldwork.

# SERVICE - SIMPLE TO USE

There are never enough hours in the day and every minute counts. That's why all Versatile tractors are designed with easy serviceability in mind. Routine service can extend the life of your tractor, minimise downtime and lower your operating costs.

## DAILY MAINTENANCE

Daily maintenance is made easy with improved access to all fill and grease points. The hydraulic and fuel sight gauges are visible from the ground without opening side panels or removing any shields. The gullwing-style side panels open wide to provide excellent service access to all under-hood components.



## AXLE SERVICING

The Versatile outboard planetary axle system is known for its ease of service. Planetary axle covers can be removed from the tractor without removing the entire undercarriage assembly, limiting the amount of time needed for routine maintenance.

## AIR CLEANER ASSEMBLY

A dry element air filter is easily accessed and removed when it needs to be replaced.

## FUELING

Refueling can easily be accomplished from either side of the tractor. A crossover tube allows both tanks to be filled quickly and with a capacity of 1800 litres you'll have many hours in the field before stopping for fuel.



A right hand ladder gives you access to the engine air cleaner for quick servicing. The ladder also helps with right side fueling and provides access to the egress door and folds up and out of the way when not in use.



The DeltaTrack was designed using the legendary Versatile outboard planetary system. In addition to doing a better job of putting power to the ground the outboard planetary is far easier to service than competitive inboard units. Removing the planetary cover exposes the planetary gears and sun gear for easy access.





## GRILLE ACCESS

The front grille swings open to provide ground level service access to the condenser / cooler package.

The cooler and condenser package swings open for service access. A reversible fan is optional on all models to increase efficiency and provide quick clean out.

The batteries are also located behind the grille at ground level and a shut off switch is standard for safety, winter storage and to prevent against theft.



## COMMON COMPONENTS

- The use of high quality components provide peace of mind that each system is reliable
- High quality components have been proven to last longer with less risk of failure
- Individual systems and operations mean the tractor is more serviceable, reducing downtime and repair costs



Versatile make sure your peace of mind continues long after your warranty expires. Simply choose an AfterCare Program suited to your requirements.



The VERSATILE brand is at the cutting edge of agricultural technology. Our goal is to supply customers with state of the art machinery that can be relied upon. This goal is carried out with determination and pride.

To further our aims we would like to introduce you to the VERSATILE AfterCare Program.

VERSATILE AfterCare gives you the opportunity to extend efficiency of your tractors. Aftercare is ideally suited to your needs, safeguarding your investment, providing you with maximum control over operating costs, ensuring long life for each product. You can rely on the high technical knowledge and professional support provided by the VERSATILE service network.

#### WHAT ARE THE BENEFITS OF AFTERCARE?

- Protection of your investment
- Minimising downtime and increasing efficiency
- Full transparency with no excess
- Fully supported by the VERSATILE Service network
- Assurance of genuine VERSATILE Parts and Lubricants
- Enhanced value for your agricultural machinery
- Improving resale opportunities and value
- Fully transferable

### WARRANTY

#### Original Parts and Components - 2-year/2000 hour

All Versatile manufactured original parts and components will be repaired or replaced as covered by the warranty if they are not free from defects in materials and workmanship.

#### Track - 4-year/2500 hour

Track warranty is assessed on a prorated basis for 4 years or 2500 hours.

### PARTS & SERVICE

Versatile dealers have access to an extensive parts supply that is well stocked with the parts for routine scheduled maintenance. Versatile maintains an extensive parts supply for tractors dating back more than 20 years.

Your Versatile dealer has factory-trained technicians that can handle everything from routine scheduled maintenance to major service and overhauls.







	520DT	620DT
<b>ENGINE</b>		
Engine type	Cummins QSX15	Cummins QSX15
Aspiration	Turbocharged & air-to-air aftercooled	Turbocharged & air-to-air aftercooled
Displacement	15-litre	15-litre
Peak horsepower	520 hp (389 kW)	620 hp (462 kW)
Horsepower @ rated speed	485 hp (362 kW)	575 hp (429 kW)
Power bulge	7% @ 1800 RPM	6% @ 1800 RPM
Torque rise	35% @ 1400 RPM	30% @ 1400 RPM
Peak torque	1650 lb-ft (2237 N•m)	1875 lb-ft (2542 N•m)
<b>FUEL SYSTEM</b>		
Capacity	475 U.S. gal (1800 L)	475 U.S. gal (1800 L)
Filter	Engine mounted w/water separator	Engine mounted w/water separator
<b>TRANSMISSION</b>		
Powershift transmission	CAT® 16 x 4 - 22 mph (35 km/hr) road speed	CAT® 16 x 4 - 22 mph (35 km/hr) road speed
<b>AXLES</b>		
Construction	Heavy-duty plate steel	Heavy-duty plate steel
Articulation angle	33°	33°
Oscillation	12°	12°
<b>AXLES</b>		
Versatile Outboard Planetary Axles	Heavy-duty	Heavy-duty
Differential Lock	Front	Front
Brakes	Dual dry caliper	Dual dry caliper
Wheelbase	154" (3900 mm)	154" (3900 mm)
<b>HYDRAULICS</b>		
Hydraulic type	Closed Center Load Sensing System	Closed Center Load Sensing System
Standard flow @ rated engine speed	53 GPM (201 L/min)	53 GPM (201 L/min)
High Flow hydraulic system @ rated engine speed	106 GPM (401 L/min)	106 GPM (401 L/min)
Hydraulic remotes	4 standard, 6 optional	4 standard, 6 optional
Maximum system pressure	2900 PSI (200 bar)	2900 PSI (200 bar)
<b>ELECTRICAL SYSTEM</b>		
Alternator	12V - 200 amps	12V - 200 amps
Batteries	3-12V, 950 CCA ea.	3-12V, 950 CCA ea.
HID lighting / Power mirrors	Optional / Optional	Optional / Optional
<b>DRAWBAR</b>		
Vertical load rating	9,000 lb (4,082 kg)	9,000 lb (4,082 kg)
Vertical load rating w/heavy-duty drawbar support	12,000 lb (5,443 kg)	12,000 lb (5,443 kg)
Hitch pin diameter (w/auto drop)	2" (51 mm)	2" (51 mm)
3-point hitch	Option	Option
<b>CAB</b>		
Cab Suspension	Standard	Standard
Volume	175.5 cu. ft. (4.97 cu. m)	175.5 cu. ft. (4.97 cu. m)
Glass	85.9 sq. ft. (8 sq. m)	85.9 sq. ft. (8 sq. m)
<b>WEIGHTS</b>		
Base tractor weight*	58,850 lb (26,694 kg)	58,850 lb (26,694 kg)
Maximum operating weight	66,900 lb (30,345 kg)	66,900 lb (30,345 kg)

\*A base tractor is considered to have a standard drawbar, no fuel, no operator, no special added equipment and no ballast.





# THE REASONS WHY

**Simple to operate, easy to service and maintain**

**Highly efficient and robust drawbar pull**

**Cummins engine, CAT transmission, Camso track technology**

**Largest cab in the industry**

**Heavy-duty frame**

Illustrations, photographs and specifications in this brochure are based on the latest information at the time of publication. Design and specification of equipment is subject to change without notice; please contact your local dealer for product information and availability. Products produced by other manufacturers featured in photography are not endorsed by Buhler Versatile Inc. and are intended for image reference only.